

Medical Vacuum Filtration

HV Series 1" - 4"

Overview

Solberg's HV Series bacterial filters for medical vacuum service are designed to offer industry leading pressure drop performance and meet demanding filtration requirements in accordance with current European and US medical vacuum standards:

ISO 7396-1:2016 Medical gas pipeline systems — Part 1 Pipeline systems for compressed medical gases and vacuum

NFPA 99:2018 Health Care Facilities Code

With its exclusive transparent design, pleated element construction, maximized element surface area, and minimal pressure drop, the HV Series offers an innovative, high quality, and long lasting solution that satisfies the strict requirements of the medical industry.

Third party verification ensures Solberg's elements meet ISO 45 H classification as defined in ISO 29463-1. The HV Series achieves greater than 99.995% total retention rate offering a very high level of protection in medical/hospital, dental, and laboratory applications.

Benefits

- Minimizes microbial contamination of vacuum pump oil and surrounding environment
- Visual pressure differential indication allows for real time monitoring and maintenance checks of the filter
- Biohazard labels improve safety and awareness at facility
- Increased surface area and large collection area maximizes contaminant holding capacity
- Low pressure drop design for reduced energy consumption over time
- Corrosion resistant and heavy duty materials of construction offer high performance and extended service life
- Isolation valve allows for quick and easy change out of glass flask for sterilization or disposal
- Equipped with pressure differential gauge for visual indication to service filter
- Easily incorporated into the medical gas distribution system piping allowing for a CE marking according to the Medical Devices Directive 93/42/EC
- High efficiency elements tested and verified to meet EN1822-1 filter class H14 requirements
- Meets NFPA 99 requirements for vacuum filtration



Rev: HV-EU0819K

HV Series 1" - 4"

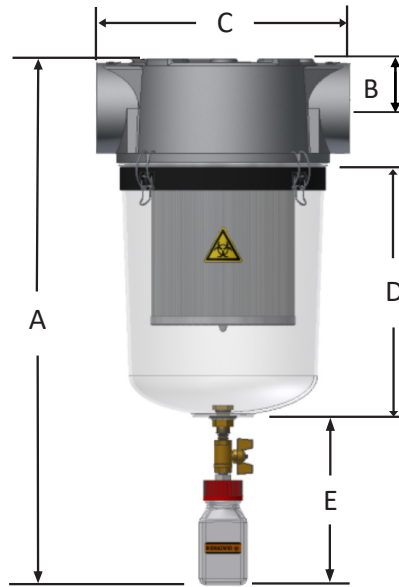

BSPB Inlet/Outlet	Assembly Part Number (w/ Gauge)	Approx. Dimensions (mm)					Suggested Service ht. mm	Approx. Weight (kg)	Replacement Element Part No.	Rarified Air Flow Rating At 370 mbar(a)	Air Flow at Atmosphere: Free Air Aspirated (FAA)
		A	B	C	D	E					
1"	HV-UL896-101C	572	305	178	264	235	214	7	UL896	186 m ³ /hr	68 Nm ³ /hr
1 ¼"	HV-UL896-126C	572	305	178	264	235	214	7	UL896	208 m ³ /hr	76 Nm ³ /hr
1 ½"	HV-UL896-151C	572	305	178	264	235	214	7	UL896	208 m ³ /hr	76 Nm ³ /hr
2"	HV-UL850/1-201C	648	362	229	318	235	222	9	UL850/1	652 m ³ /hr	238 Nm ³ /hr
2 ½"	HV-UL850/1-251C	648	362	229	318	235	222	9	UL850/1	652 m ³ /hr	238 Nm ³ /hr
3"	HV-UL234/2G-301C	737	432	343	356	235	244	14	UL234/2G	1,052 m ³ /hr	384 Nm ³ /hr
4"	HV-UL234/2G-401C	737	432	343	356	235	244	14	UL234/2G	1,052 m ³ /hr	384 Nm ³ /hr

6" option available upon request.

Technical Specifications

- Operating pressure range: atmospheric to full vacuum
- Particulate removal > 99.995% efficiency
- Meets ISO 29463-1 requirements for ISO 45H class filtration
- Temp (continuous): min -15°F (-26°C) max 220°F (104°C)
- Corrosive resistant aluminum cast head
- Shatter resistant polycarbonate collection area
- Glass drain flask for easy removal and sterilization

Options

- Available with or without gauge (Standard HV part number includes gauge.)
- For information on a unit without gauge, please contact the factory.
- Taps for gauges and mounting brackets



SOLBERG®

www.solbergmfg.com

All model offerings and design parameters are subject to change without prior notice.
Contact your representative or Solberg for the most current information.

Technical Data

Inlet Vacuum Filters

Applications & Equipment

- Industrial & Severe Duty
- Vacuum Pumps & Systems: Roots, Rotary Vane, Screw, Piston
- Vacuum Packaging Equipment
- Vacuum Furnace
- Blowers: Side Channel & P.D.
- Vacuum Lifters
- Intake Suction Filters
- Food Industry
- Woodworking/Routers
- Ash Handling
- Printing Industry
- Medical/Hospital
- Remote Installations for Piston & Screw Compressors
- Paper Processing
- Waste Water Aeration
- Cement Processing
- Bag House Systems
- Vacuum Vent Breathers
- Chemical Processing
- Factory Automation Equipment
- Leak Detection Systems

Identification

Standard Solberg assemblies should have an identification label/nameplate that gives the following information:

- Assembly Model #
- Replacement Element #

The part number designates the filter type, the element configuration and housing connection size. For example, the following part number identifies the filter as being a “CSL” design filter with a “235” element, “P” prefilter and DN100 flange connection size.

CSL-235P-DN100

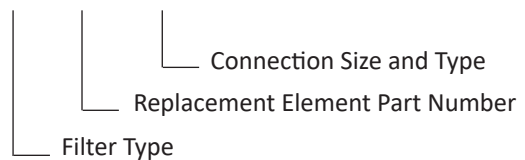

Vacuum Service Rating Chart

Threaded vacuum filter connections must be free of defect and properly sealed to achieve deeper vacuum levels. Vacuum service levels are given for reference only and serve as a guideline for product selection. Product certification and alternative designs are available for applications requiring deeper vacuum levels and specific leak rates. Please contact factory for details.

Vacuum Level	Pressure (mbar)	Pressure (Torr)	Pressure (Pa)
Atmospheric Pressure	1013	760	1.013x10 ⁵
Coarse Vacuum	1013 to 33	760 to 25	1x10 ⁵ to 3x10 ³
Medium Vacuum	33 to 1.3x10 ⁻³	25 to 1x10 ⁻³	3x10 ³ to 1x10 ⁻¹
High Vacuum	1.3x10 ⁻³ to 1.3x10 ⁻⁹	1x10 ⁻³ to 1x10 ⁻⁹	1x10 ⁻¹ to 1x10 ⁻⁷

Rev: InletVacTech-EU0719K

Inlet Vacuum Filters

Choosing the Best Filter for Your Equipment

A. When the connection & airflow is known:

1. select the appropriate connection style. (i.e.: BSPT, Flange, BSPP, etc.)
2. check assembly m³/hr (flow) rating. Compare with your required airflow.

(Note: Assembly flow ratings are based on 6,000 FPM or 30m/sec for a given connection size to achieve low pressure drop performance. When required flow exceeds assembly flow rating, the pressure drop through the outlet connection will increase. In such cases select by element m³/hr (flow) rating.)

3. when required flow rating matches connection size; skip to "C. Selecting Elements".

B. When the connection size is unknown, flexible, or the required flow rating exceeds assembly flow rating:

1. match required flow rating with the element flow rating.
2. choose related connection size.

C. Selecting Elements: The filter performance is influenced by the actual application duty and the equipment it is installed on. Regular maintenance checks and proper servicing is required.

Application Duty Descriptions:

Industrial Duty: clean workshop or clean outdoor environment - small element sizing is sufficient.

Severe Duty: dirty workshop, wastewater – medium to large element is recommended.

Extreme Duty: cement, steel making, plastics or dusty material conveying – largest element sizing is recommended.

1. Select media required by your application. Options include:

a. Standard media

1. Polyester: all purpose; withstands pulses, moisture, and oily air
2. Paper: mostly dry, smooth flow applications

b. Special Media: for a variety of micron levels and media types, see the "Filter Media Specifications" in the Replacement Element Section or contact Solberg.

2. Select element size by matching the element with the anticipated duty and upsize accordingly.

Filter Assembly Maintenance

Request the appropriate maintenance manual for more in-depth information from your Solberg representative or on our website: www.solbergmfg.com.

Element Maintenance

Solberg elements should be replaced once the pressure drop reaches 37-50 mbar above the initial pressure drop of the installation. Cleaning the element is also an option.

Solberg recommends replacing dirty elements for optimal performance. Any damage which results from by-pass or additional pressure drop created by element cleaning is the sole responsibility of the operator.

Note: The overall performance of a filter element is altered once cleaned. The initial pressure drop after subsequent cleanings will be greater than the original, clean pressure drop of the element. After each cleaning, the pressure drop will continue to increase. Under all circumstances, the initial pressure drop of the element needs to be maintained at less than 37 mbar.

If the pressure drop exceeds 50 mbar at start-up; it should be replaced with a new element. With many types of equipment, the maximum pressure drop allowed will be dictated by the ability of the equipment to perform to its rated capacity. Under all circumstances, the operator should avoid exceeding the manufacturer's recommended maximum pressure drop for their specific equipment.



SOLBERG

www.solbergmfg.com

All model offerings and design parameters are subject to change without prior notice.
Contact your representative or Solberg for the most current information.